

DMSF™

Double Monolithic Stationary Flow

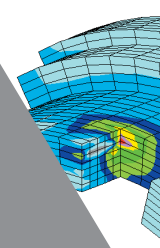

- Improve plant uptime and reduce maintenance costs
- World-leading barrier fluid pumping and seal face cooling
- Designed to withstand barrier and process pressure fluctuations
- Internationally patented design



“Our purpose is to give our customers such exceptional service that they need never consider alternative sources of supply.”

DMSF™ — High Performance Sealing Solution

AESSEAL® is a leading global specialist in the design and manufacture of mechanical seals, bearing protectors and seal support systems.

The company sets new standards in reliability, performance, service and cost. Service has been the key to the success of AESSEAL® and is at the core of the company purpose statement — ‘to give our customers such exceptional service that they need never consider alternative sources of supply.’ Through continuous investment, unique modular technology and an unparalleled dedication to customer service we aim to constantly exceed expectation.

Industry leading modular design is proven to decrease costs and increase equipment uptime.

The AESSEAL® DMSF™ range of double cartridge mechanical seals has been designed as a high performance sealing solution for arduous applications.

The current range of DMSF™ mechanical seals is the result of over 3 years extensive evaluation and development. AESSEAL® believes that the DMSF™ is the most technologically advanced mechanical seal in its class. The DMSF™ is not a replacement for the highly successful CDSA™ range. The unique DMSF™ design features extend the range of applications that can be sealed by AESSEAL® products.

The DMSF™ is part of the AESSEAL® modular sealing system. This, combined with extensive inventory levels, ensures that **any** standard seal in any size or material combination is available for immediate despatch. This means you can get an application specific seal quickly and therefore hold less inventory.

AESSEAL Global Technology Centre



Extensive AESSEAL® test facilities



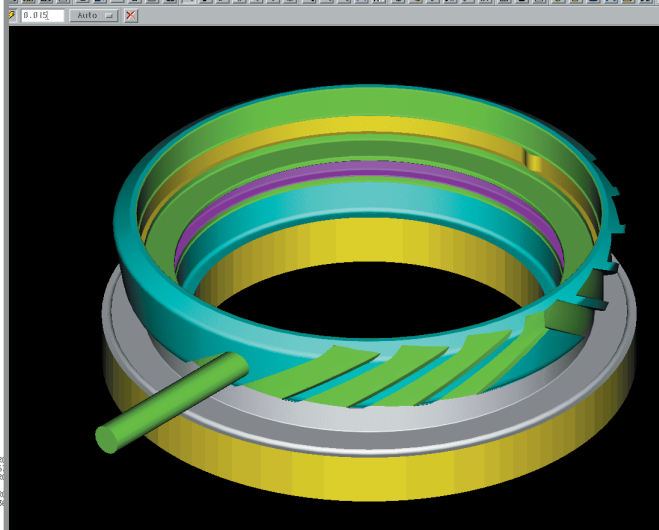
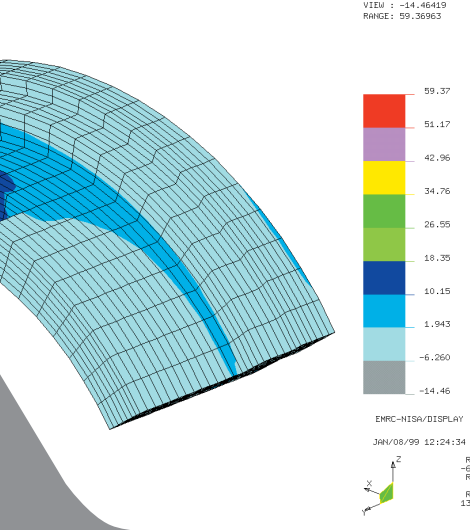

Finite Element Analysis computer simulation (left), Manufacturing Verification Animation (centre), CNC CMM inspection (right)

DMSF™ — Design and Development

The DMSF™ seal design was created as a result of a request from a major AESSEAL® customer who required a set of seal design features which was not satisfied by one existing AESSEAL® product.

The design evolved after a comprehensive market review of existing seal designs and best engineering practice. Inevitably, as with the majority of our designs, new and novel patented features were developed, helping to ensure that the final product would excel in some of the most difficult and arduous applications found on-site.

Thorough design simulation using Computer Aided Engineering (CAE) and Finite Element Analysis (FEA) was conducted prior to physical tests. This computer evaluation helped to increase the reliability of the prototypes and reduce the seal development time.

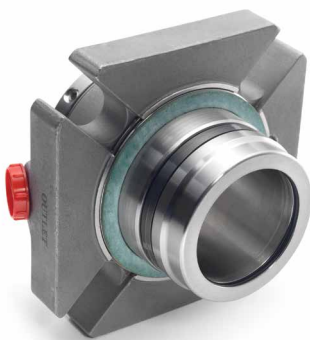

DMSF™



DMSF™ ANSI+ size

The DMSF™ commanded the most extensive test program that the company had ever undertaken. These tests included stop/start, cyclic temperature, flow and duration tests, at various seal sizes and seal face combinations.

Furthermore, the design was rigorously benchmarked against and outperformed similar products in its class in many sealing attributes.

This world class product is complemented with the use of state-of-the-art manufacturing methods and equipment, ensuring that the technically sophisticated design is produced to exacting standards.



DMSF™ — Design Features

Monolithic Seal Faces

All seal faces are of monolithic, one piece, construction and therefore are less likely to distort in high and low temperature applications.

Double Hydraulically Balanced Seal Faces

Inboard seal faces are **double balanced** helping to ensure excellent sealing at high or low barrier to process pressure differentials. Double pressure balanced inboard seal faces minimize seal face distortion and help to ensure stable fluid film conditions between the seal faces.

Reliable Face Drive Mechanism

Finite Element Analysis has been used to optimize seal face drive. Precise, solid machined drive lugs/pins reduce drive slop between the drive ring and seal face. This is beneficial on equipment start-up / shut-down when using monolithic brittle face materials such as Silicon Carbide or Carbon.

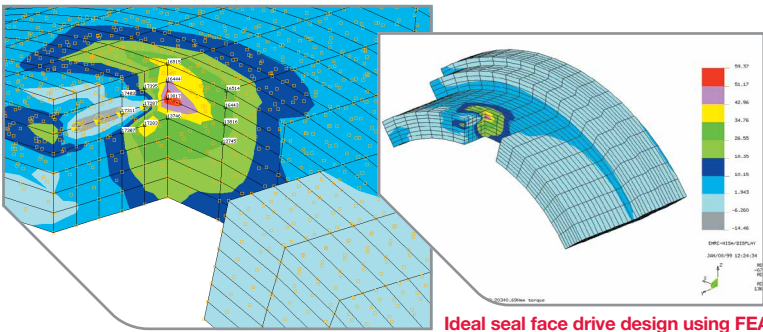

Seal Face Heat Generation

Some seal designs use a modular 'wide' running seal face in both inboard and outboard positions.

All outboard DMSF™ seal faces are 'thin-faced'. This ensures minimal outboard heat generation, which minimizes the 'heat dump' requirements of the seal support system.

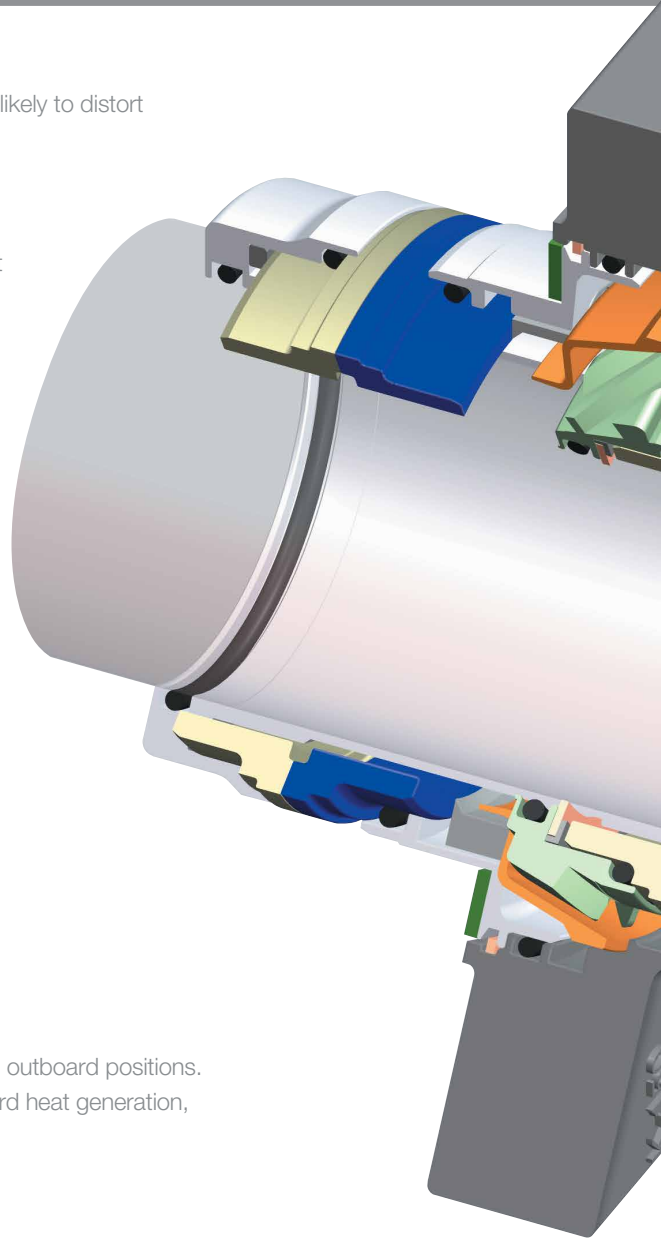

DMSF™ — a unique >bi-directional< pumping ring

Unique Barrier Pumping Design — The unique, patented, bi-directional, integral pumping design delivers high volumes of barrier fluid to the inboard and outboard seal faces.

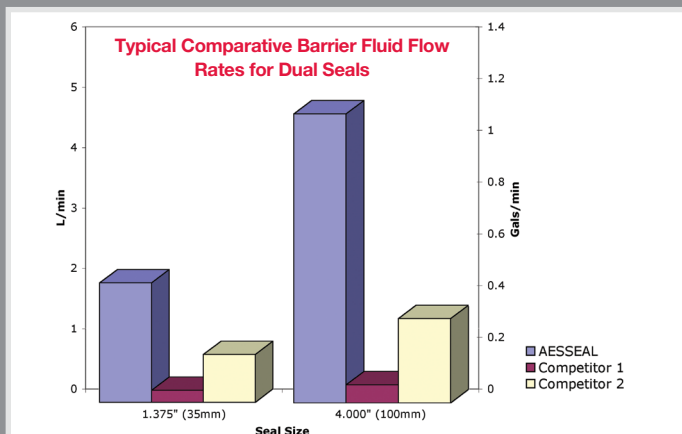



Materials of Construction Flexibility

The gland insert design enables cost effective alternative wetted materials to be offered, whilst maximizing component modularization, reducing on-site inventory levels, reducing repair costs and improving customer service.

Maximum Barrier Fluid Flow

All environmental control ports are 3/8" NPT, helping to maximize the internal cooling affects within the seal. The outlet port is positioned directly over the outboard seal faces ensuring constant fluid replacement where it counts.

Equipment Shaft Growth

The range of large DMSF™ seals accommodate axial thermal shaft growth of +/-0.040" (+/-1.0mm).

Self Aligning Stationary Seal Faces

Both stationary seal faces are spring loaded and compensate for mis-alignment between the shaft and the housing.

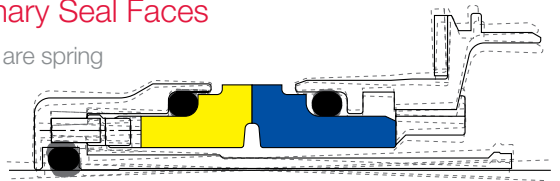

High Shaft Speed Applications

The stationary seal construction helps to minimize spring fatigue for optimum performance on high shaft speed applications.

Ultimate Flexibility

The range of large DMSF™ inboard and outboard rotary seal faces are dimensionally inter-changeable. This allows the seal to be offered in a multitude of configurations in addition to the standard product offering.

DMSF™ — unique >directed< barrier fluid

Inboard Seal Face Cooling — The majority of Flow Induced mechanical seal designs create a churning action with little or no barrier fluid flow. This has a limited effect on seal face cooling.

The DMSF™ has a stationary deflector which directs barrier fluid underneath the inboard faces ensuring constant barrier fluid replacement at the hottest and most important point on all mechanical seal designs.

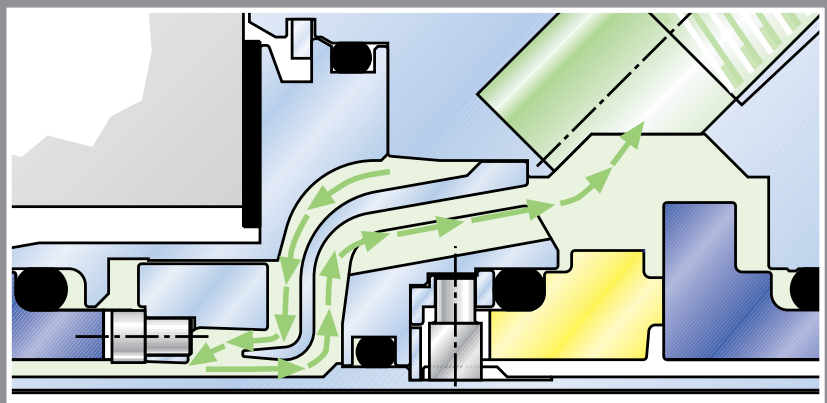

DMSF™ – Technical Information

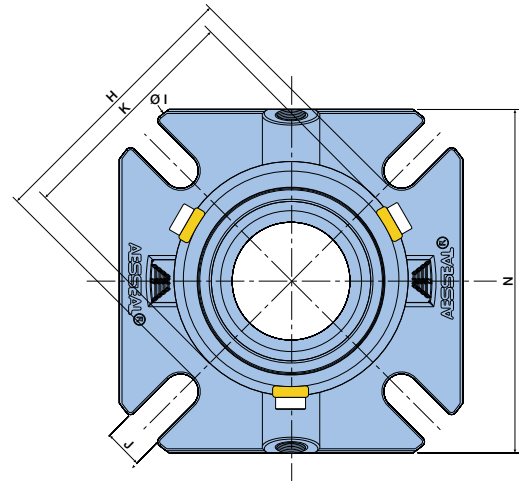
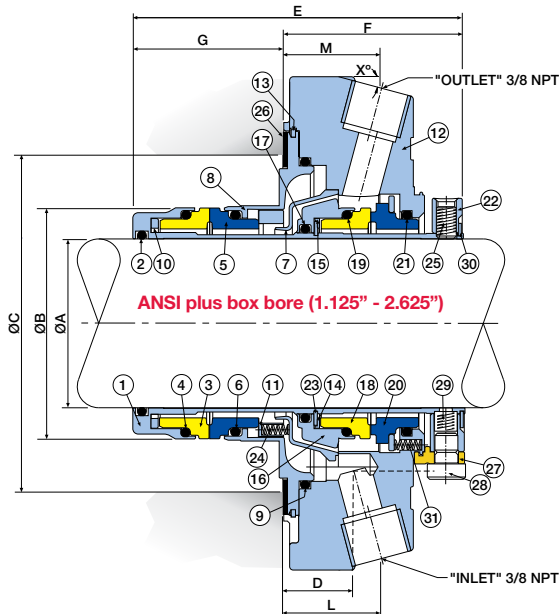
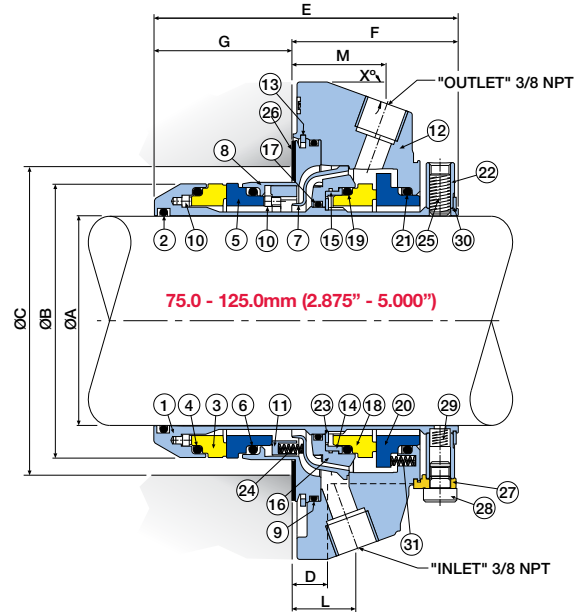
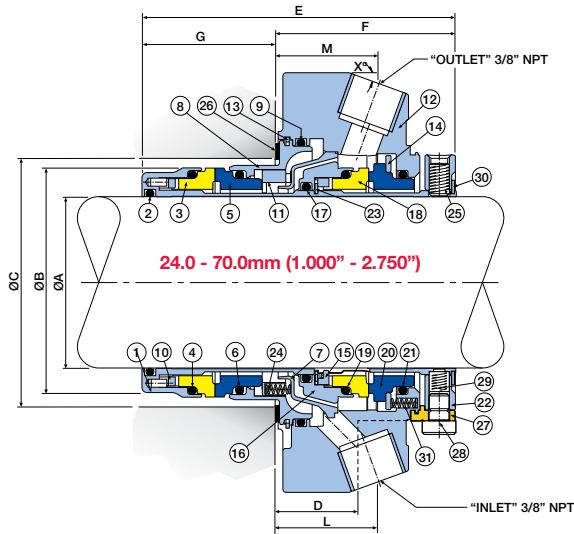

Standard ISO / ANSI box bore gland format

Item	Description	Material
1	Sleeve	316L SS
2	Sleeve O Ring	Viton® / EPR / Kalrez® / Atlas®
3	Internal Rotary Face	Carbon / SiC / TC
4	Internal Rotary Face O Ring	Viton® / EPR / Kalrez® / Atlas®
5	Internal Stationary Face	Carbon / SiC / TC
6	Internal Stationary Face O Ring	Viton® / EPR / Kalrez® / Atlas®
7	Deflector	316L SS
8	Gland Insert	316L SS
9	Gland Insert O Ring	Viton® / EPR / Kalrez® / Atlas®
10	Internal Drive Ring/Pin	Stainless Steel
11	Internal Spring Plate	316L SS
12	Gland	316 SS
13	Gland Insert Snap Ring	Stainless Steel
14	External Drive Ring/Spring Plate	316L SS
15	External Drive Ring/Pin	Stainless Steel
16	External Rotary Holder	316L SS
17	External Rotary Holder O Ring	Viton® / EPR / Kalrez® / Atlas®
18	External Rotary Face	Carbon / SiC / TC
19	External Rotary Face O Ring	Viton® / EPR / Kalrez® / Atlas®
20	External Stationary Face	Carbon / SiC / TC
21	External Stationary Face O Ring	Viton® / EPR / Kalrez® / Atlas®
22	Clamp Ring	316L SS
23	Circlip	Stainless Steel
24	Springs	Alloy 276
25	Drive Screws	Stainless Steel
26	Gasket	AF1 / GFT
27	Setting Clips	Brass
28	Setting Clip Screws	Stainless Steel
29	Anti-tamper Screws	Stainless Steel
30	Circlip	Stainless Steel
31	Springs	Alloy 276



Exotic Alloy Seals

Contact AESSEAL® for availability of Exotic Alloy options.

Important - some glands are manufactured from castings and therefore the angle and position of the port should be checked. If in doubt, please contact the AESSEAL® technical department.

DMSF™ — Seal Support Systems

AESSEAL® high performance barrier fluid systems help to increase plant uptime even further by enhancing the environment in which mechanical seals operate. Many of these barrier fluid systems are patented, which means that the technology is exclusive to AESSEAL®. A small selection of these is shown below, for more information please visit www.aesseal.com/systems.aspx.



SWFF-TF™ — Flow Fuse™ Water Management System

- **Flow-sensing shut-off valve** — Protects the process from barrier fluid contamination upon catastrophic seal failure
- **Water regulator** — Maintains water level and pressure in the vessel
- **Automatic re-set facility** — Protects the mechanical seal from running dry during a process upset
- **Thermal relief valve** — Maintains system pre-set pressure by accommodating any thermal expansion



SW Range (SW2™ and SW3™) — Water Management Systems

- **10 / 25 litre (2.8 / 6.6 gal US) 304 SS vessel construction** — Suitable for a range of challenging environments
- **Water regulator** — Maintains water level and pressure in the vessel
- **Flow indicator** — Visually alerts the user to an inboard seal failure
- **Non-return valve** — Protects plant water supply from contamination, and maintains vessel pressure in the event of supply interruption
- **Available with / without cooling coil** — Additional heat dump available if required



AES-15™ Systems

- **316 SS vessel construction** — Suitable for challenging plant environments
- **Higher pressure** — Suitable for a wide range of arduous environments. Vessel design rating 30 barg @ 200°C (435 psig @ 392°F)
- **Enhanced modular design** — Suitable for both American and European site applications
- **Cooling coil as standard** — Increases the surface area available for barrier fluid cooling



FDU™ — Fluid Distribution Unit

- **Independent pressurised fluid supply system** — Removes the expense of piping a pressurised clean water / oil supply to a new area of the plant
- **Feeds a number of seal support systems** — Removes the expense of purchasing one system per seal
- **Optional pressure switch and accumulator** — Enables greater control of water / oil line pressure
- **Reduced energy consumption** — The system can be operated intermittently to reduce energy costs via dead-ended piping

For further information and safe operating limits contact our technical specialists at the locations below.



Use double mechanical seals with hazardous products.

Always take safety precautions:

WARNING

- Guard your equipment
- Wear protective clothing

UK Sales & Technical advice:

AESSEAL plc
Mill Close
Bradmarsh Business Park
Rotherham, S60 1BZ
United Kingdom
Tel: +44 (0) 1709 369966
Fax: +44 (0) 1709 720788
E-mail: seals@aes seal.com

Distributed by:

'Our purpose is to give our customers such exceptional service that they need never consider alternative sources of supply.'



USA Sales & Technical advice:

AESSEAL Inc.
355 Dunavant Drive
Rockford,
TN. 37853
USA
Tel: +1 865 531 0192
Fax: +1 865 531 0571
E-mail: usa@aes seal.com

Important: Since the conditions and methods of use of this product are beyond our control, AESSEAL plc expressly disclaims any and all liability resulting or arising from any use of this product or reliance on any information contained in this document - AESSEAL plc standard conditions of sale apply. All sizes are subject to manufacturing tolerances. We reserve the right to modify specifications at any time. AESSEAL® is a Registered Trademark of AESSEAL plc, AESSEAL plc recognizes all trademarks and trademark names as the property of their owners.